

Techsense Bangladesh Ltd

Gripper With Two Parallel Jaws Series P2, Code- W1570160200

Double-acting system with clamping in both directions.
 All the grippers come with magnet and sensor slots.

TECHNICAL DATA		P2-16	P2-20	P2-25
Operating pressure	bar		2 to 8	
	MPa		0.2 to 0.8	
	psi		29 to 116	
Operating temperature	°C		-10 to +80	
Maximum operating frequency	cycles/s		2	
Fluid		20 µm filtered, lubricated or unlubricated air; lubrication if used, it must be continuous.		
Size		16	20	25
Bore	mm	16	20	25
Single jaw stroke	mm	4	5	7
Clamping force at 6.3 bar 20 mm from the top surface during opening and closing	N	45	100	135
Weight	kg	0.2	0.4	0.75

General Attributes

- Type : P2-16
- Diameter (Bore) : 16 mm
- Stroke : 4 mm
- Weight : 0.2 kg



DIMENSIONS OF GRIPPER P2-16

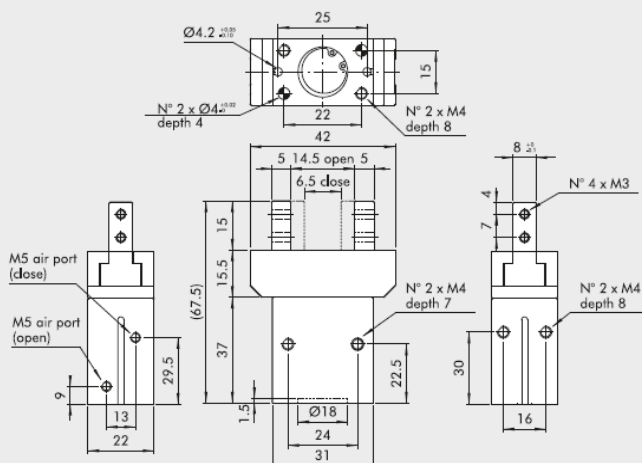

Code	Description
W1570160200	Gripper with 2 parallel jaws P2-16

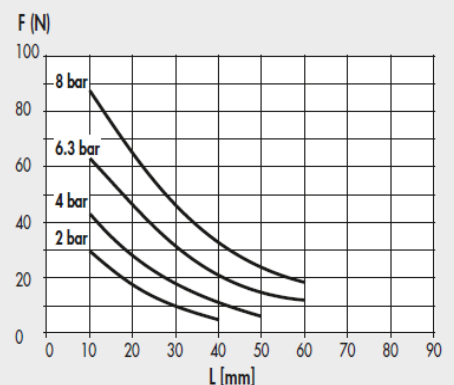

For further information please visit : <https://goo.gl/wfoWWW>



We are the authorized distributor of Metal Work in Bangladesh.

